



CNC control panel iOP-19-TFT

Operating instructions

www.isel.com
isel[®]

Abbreviations used in these

operating instructions

MRL	<i>Machinery Directive 2006/42/EC</i>
ERL	<i>EMC Directive 2004/108/EC</i>
NRL	<i>Low Voltage Directive 2006/95/EC</i>

Symbols used

The operating instructions contain important information / issue and danger symbols, which must be noted and complied with:



Warning!

This symbol warns of potential danger to health, life and limb.



Warning! Potentially lethal voltage

This sign warns of danger to life and limb due to the presence of high-voltage electrical circuits. Failure to observe the danger can result in severe injury or death.



Attention!

This symbol means important instructions are being given. Failure to observe the instructions may result in equipment malfunction or damage to machinery.



Information:

This symbol means important information or advice is being given.

Complying with safety information



Prior to using the iOP-19-TFT CNC control panel or making any alterations to the electrical installations in or on your machinery, please ensure that you have carefully read through the safety information in these operating instructions.

The information, technical specifications and dimensions contained in this booklet represent the latest available data at the time of going to print. The occurrence of misprints and other errors cannot, however, be completely ruled out. We thank you in advance for bringing such errors to our notice and we welcome any improvement suggestions you may have.

We are obliged to draw your attention to the fact that the software and hardware brand names and trade marks appearing in this booklet are protected under patent.

All rights reserved. No part of this booklet may be reproduced, electronically processed, duplicated or distributed in any form whatsoever (printed out, photocopied, etc.) without the written permission of **isel Germany AG**.



isel Germany AG machines and controllers are CE compliant and labelled accordingly. This equipment must not be operated until the CE safety guidelines applying to all associated machinery parts and components have been fully complied with.



isel Germany AG accepts no liability for damage to equipment or malfunction where modification has been made to the controller.



The EMC test is only valid for CNC control panels with original ex-works configurations.

Manufacturer: **isel Germany AG**
Buergermeister-Ebert-Straße 40
D-36124 Eichenzell

Tel.: +49 (0) 6659 981-0
Fax: +49 (0) 6659 981-776
Email: automation@isel.com
<http://www.isel.com>

Article No. : 371100 1000 (**original operating instructions**)

Date of issue: 06/2014_RL

Technical specifications may change without prior notification.
Current operating instructions and equipment manuals can be downloaded at:

www.isel-data.de/manuals

Table of contents

- 1 General Information 5**
 - 1.1 Safety information..... 5

- 2 Product description 6**
 - 2.1 Versions..... 6
 - 2.1.1 CNC control panel iOP-19-TFT with 19“ touch screen 6
 - 2.2 Description of control elements 7

- 3 Connections of the control elements 10**
 - 3.1 Connection of the controls for the control PC..... 10
 - 3.2 Power supply for the CNC control panel 11
 - 3.3 Connection of machine controls..... 12

- 4 Faults 13**

- 5 Service and maintenance 13**

- 6 Technical Data 14**
 - 6.1 Technical Data iOP-19-TFT..... 14

- 7 EC Declaration of Conformity 15**

1 General

Please read these operating instructions through to the end and carefully follow the instructions given. Failure to comply with these operating instructions can result in damage to property, personal injury or death.

1.1 Safety note



- The iOP-19-TFT CNC control panel is designed in accordance with state of the art technology and in full compliance with recognised safety standards.
- This equipment must only be operated in a fault-free condition. Any observed defect must be removed before the equipment is used. This equipment must only be operated by trained personnel. Children should not be allowed in the vicinity of the equipment.
- This equipment must only be used in accordance with its intended purpose, i.e. for the monitoring and control of CNC machinery linked to a separate iSR/iPC series control computer.
- Equipment operations must only be carried out by authorised, qualified personnel and in full compliance with electrical industry regulations and safety standards. Ensure the equipment is fully disconnected from the mains supply before opening the cover and carrying out any electrical installation work.
- Ensure there is sufficient ventilation in the immediate vicinity of the monitor. Ensure the equipment is mounted in a safe and stable position and that the ventilation ports in the monitor housing are left open and unobstructed.
- Equipment assembly and operation must be undertaken in compliance with all relevant conformity declaration standards. The guidelines and threshold values issued by the manufacturer do not provide protection in the event of improper use of the equipment.
- The equipment must not be exposed to excessive levels of humidity or vibration.
- Ensure that all operators are familiar with the content of these operating instructions and that such content is strictly adhered to at all times!

2 Product description

2.1 Versions

Type	Description	Article No.
<i>iOP-19-TFT</i>	without keyboard, RAL 3011	371100 1000
<i>with German keyboard, (optional)</i>	with silicon keyboard, RAL 3011	371200 0001
<i>with English keyboard, (optional)</i>	Silicon keyboard, RAL 3011	371200 0002

2.1.1 CNC control panel iOP-19-TFT with 19" touch screen

standard



- robust aluminium housing
- Aluminium "stainless steel-look" front panel
- Simple assembly using VESA 100/100 mounting
- Integrated machinery control elements
- 19" TFT with touch screen
- Max. resolution: 1280 x 1024 pixels
- 3 USB connections
- pull-out connecting cable, compatible with isel control computer

optional

- Stand
- Swivel arm for connection to PS profile
- Simple keyboard / mouse storage compartment
- Superior quality, built-in 105-key silicon German / English keyboard with touch pad
- Two-handed operation
- Override potentiometer
- Available in 3 colours, RAL 3011, RAL

2.2 Description of control elements

In the standard version, the most important control elements (buttons, switches) are mounted on the CNC control panel.

Machinery control elements

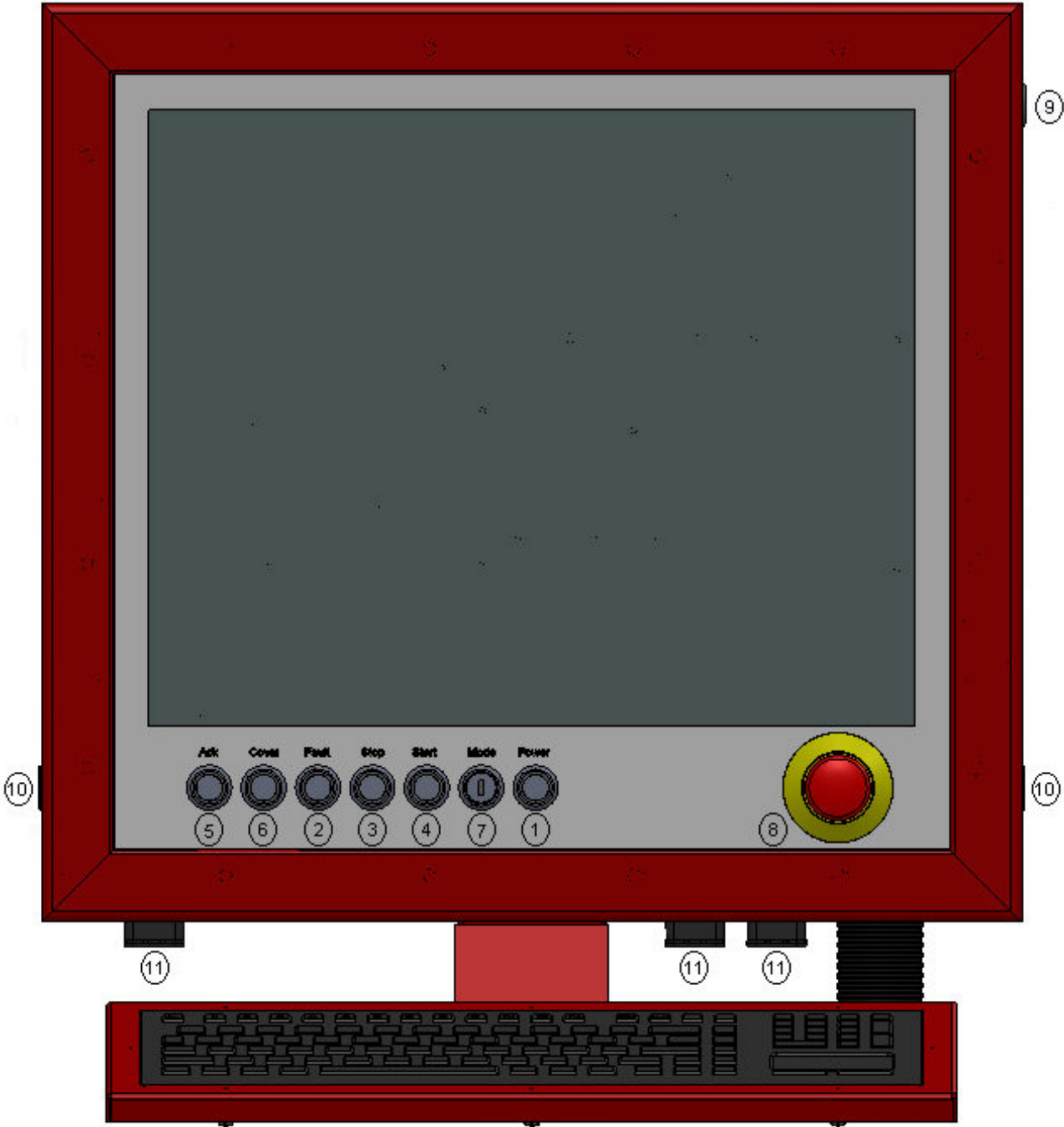

No.	Element	Description
1	Power ON button	Switches the power amplifiers on.
2	Fault indicator	The fault indicator signals the presence of a fault in the safety circuit.
3	STOP button	Interrupts the NC program currently being executed. Pressing the STOP button a second time terminates the NC program currently being executed (does not apply to all control configurations, only to the ProNC setting).
4	START button	Pressing the START button initiates execution of the current NC program or, where the program has been interrupted, allows the current program execution to be continued.
5	ACK (acknowledge) button	The ACK button is used in Set Up mode and must be pressed to allow the shafts to be driven when the cover is open.
6	COVER button	The COVER button is pressed to allow the cover to be opened (where a cover has been provided). The cover can only be opened when the conditions listed under "Operating Mode Selector Switch" have been fulfilled. Once the white signal lamp on the COVER button is illuminated, the cover can be opened.
7	Operating Mode Selector Switch	This key switch allows the unit to be switched between the Automatic Operation and Set Up modes. In Automatic Operation, the cover (or door) of the machine can only be opened when the shafts are not in motion and the cutting spindle has been switched off. In the Set Up mode, the cover (or door) of the machine can only be opened when the working spindle has been switched off. In the Set Up mode, the shafts can be activated with the cover open by pressing the ACK acknowledgement button.
8	EMERGENCY STOP button	Pressing this button immediately disconnects the power supply to the motor, converter and working spindle.



Switching into the AUTO ->TEST operating mode whilst the workpiece is being machined brings the working spindle to a halt. Switching back to the AUTO mode restarts the working spindle. Before switching back to the AUTO operating mode, ensure that all moving parts are in the stop position. Failure to do this can result in damage to the working spindle or workpiece.

No.	Element	Description
9	PC START button	Switches the computer "on" and "off".
10	Two-handed operation	Control buttons for two-handed operation (optional)

Control computer control elements

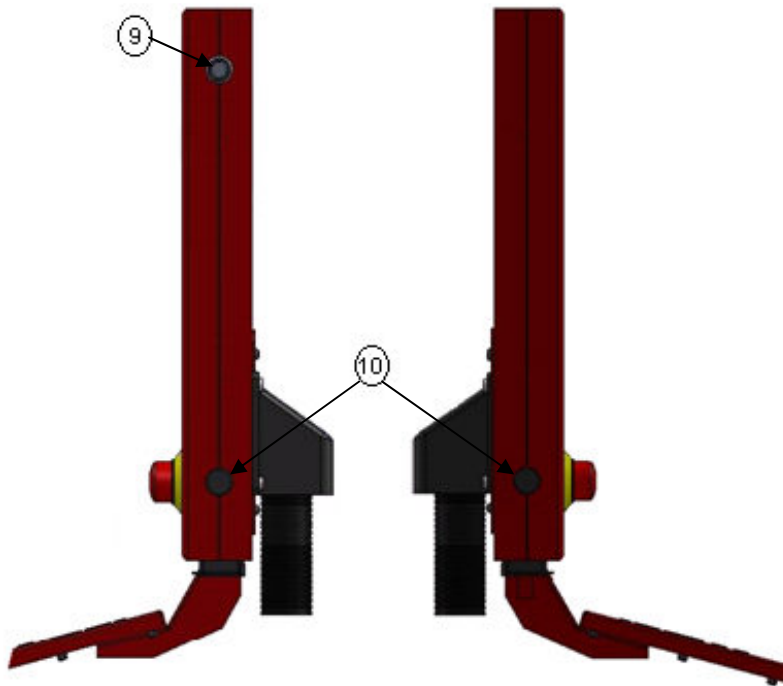

No.	Element	Description
11	USB connections	<p>The iOP-19-TFT is fitted with an integrated USB hub. This provides integrated touch screen connection. The three USB ports allow equipment such as USB sticks, a USB keypad, a WIBU dongle or an external CD ROM drive to be connected.</p> <p>i <i>The USB hub is provided with its own +24V power supply (active USB hub). Power is fed to the hub via the machinery control element connecting cable (see Chapter 3).</i></p> <p><i>If the CNC control panel has been connected to an isel computer not fitted with a +24V supply (e.g. iPC15), the touch screen and USB ports will remain inoperative.</i></p>

Screen control elements

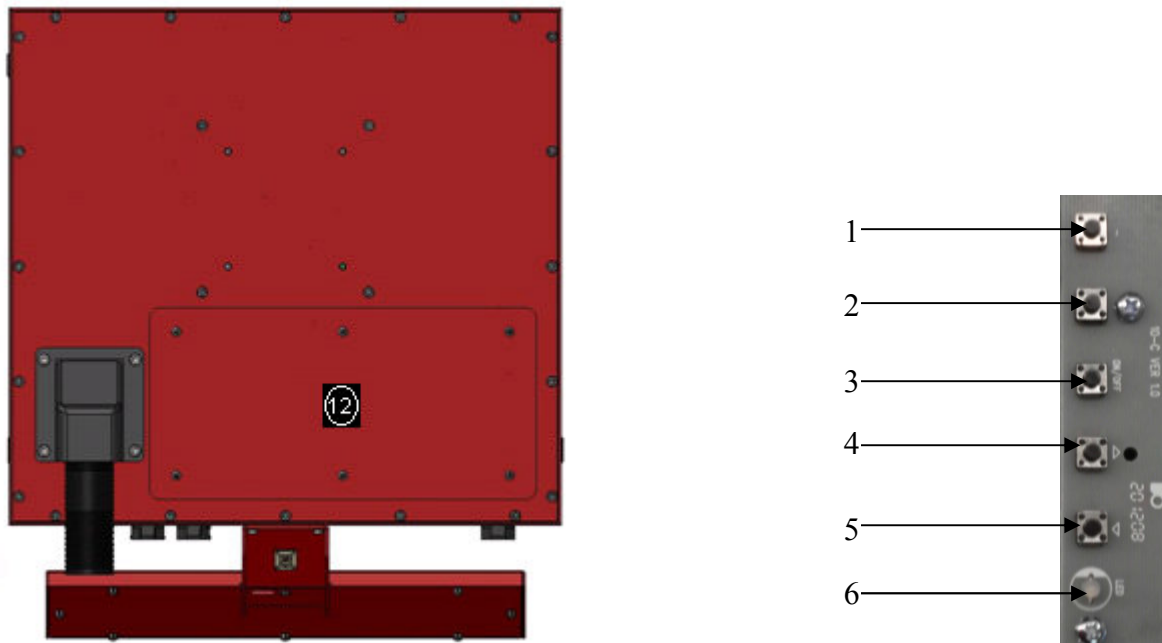

12 The screen control elements are located in the service hatch

No.	Element	Description
1	Menu (top)	Use the menu to navigate to the top
2	Menu (bottom)	Use the menu to navigate to the bottom
3	ON / OFF	Switches the monitor "on" and "off"
4	Menu (enter)	Opens the menu / confirms settings
5	Menu (back)	Steps the menu back one level
6	LED	Indicates operating condition: red → off, green → on

3 Control element connection



All CNC control panel connecting cables are optimised for use with isel iSR/iPC series control computers. These connecting cables should not be extended. Doing so may impair the performance of the CNC control panel.



Ensure the protective earth conductor is adequate with a diameter of at least 2.5mm² (screened cable) or 4mm² (un-screened cable) and connected between the iOP-19 terminal \perp and the safety bus bar of your machine!

3.1 Connecting the control PC control elements



DVI connecting cable

This cable is fitted with a DVI plug for connection to the graphic card of your computer.

USB hub connecting cable



Plug this cable into any free USB port on the control computer. Connecting the cable allows the integrated keyboard, in-built LCD touch screen and the two side-mounted USB ports to be used.



The USB hard drive cannot be used without first connecting an external power supply to the USB ports. This is because the USB ports alone are unable to supply sufficient power.

3.2 Power supply to the CNC control panel

D-sub 9-pin plug



This plug must be used with the isel iSR/iPC series control computer. It allows the power button connecting cable to be plugged into the right-hand side of the CNC control panel, the indicator LEDs into the front panel of the equipment cover and the TFT power supply into the socket provided on the control computer. Insert the plug into the D-sub socket provided on the control computer in the switching cabinet.

Pin	Labeling	Description
1	PWR BTN +	Power button connection +
2	PWR BTN GND	Power switch connection GND
3	PWR LED +5V DC	LED indicator lamp connection +
4	PWR LED GND	LED GND indicator lamp connection
5	HDD LED +5V DC	HDD LED indicator lamp connection +
6	+12V DC	Power supply for the 19" TFT +12V
7	GND	Power supply for the 19" TFT GND
8	not available	
9	HDD LED GND	HDD LED indicator lamp connection GND

Jack plug connection when using an external power supply unit 12V DC/60W power supply



Always make sure that only one power connection is provided. Use either the D-sub 9-pin plug or the jack.

3.3 Machine control element connection



D-sub 25-pin plug control element

This cable allows the control elements (buttons and switches) on the front cover of the CNC control panel to be connected to the corresponding safety circuit modules in the switching cabinet.

Pin assignment for the D-sub 25-pin plug

Pin	Signal	Labeling
1	EMERGENCY STOP_1	EMERGENCY Stop Channel 1, Connection 1.1
2	EMERGENCY STOP_1	EMERGENCY Stop Channel 1, Connection 1.2
3	EMERGENCY STOP_2	EMERGENCY Stop Channel 2, Connection 2.1
4	EMERGENCY STOP_2	EMERGENCY Stop Channel 2, Connection 2.2
5	24V	+24V DC
6	POWER BTN	Power button input
7	POWER LAMP	Power lamp output
8	24V	+24V DC
9	KEY SWITCH Test	Key switch input test mode
10	KEY SWITCH Auto	Key switch input automatic operating mode
11	24V	+24V DC
12	ACK_1	Channel 1 enabling switch input
13	24V	+24V DC
14	ACK_2	Channel 2 enabling switch input
15	COVER SWITCH	Cover switch input
16	COVER SWITCH	Cover switch output
17	GND	
18		
19		
20	FAULT LAMP	Control panel fault lamp output
21	START BTN	Start button (closing contact)
22	STOP BTN	Stop button input (opening contact)
23	START LAMP	Start lamp output
24	STOP LAMP	Stop lamp output
25	not available	



Power (+24V DC) to the USB hub on the control panel is provided by this cable.

Make sure that the keyboard, touch screen and USB interfaces only function when connected to the safety circuit modules.

4 Malfunctions

Fault	Action
No screen display on the monitor	<ol style="list-style-type: none"> 1 Check that the control computer is switched on. 2 Check the PC START button connecting cable and make sure the computer is switched on. 3 Check the power supply (D-sub 9-pin plug at the iPC) 4 Check the POWER ON control lamp is illuminated. If not, switch the monitor on with the Power On/Off button. 5 Check whether the resolution setting can actually be displayed by the monitor. If necessary, reset the resolution by starting the computer in safety mode and then adjusting the screen resolution.
The screen image is blurred or distorted.	<ol style="list-style-type: none"> 1 Use the button provided to automatically calibrate the monitor.
The equipment cannot be controlled using the control panel.	<ol style="list-style-type: none"> 1 Check the D-sub 25-pin plug connection to the safety circuit module. 2 Check the software signal settings (these affect the START / STOP button)
The integrated touch screen and keyboard do not function	<ol style="list-style-type: none"> 1 Check that power is provided to the integrated USB hub. Power is being provided to the safety module via the machinery control element cable and D-sub 25-pin plug. 2 Check that the USB cable is properly connected to the control computer.

5 Maintenance and servicing

Maintenance

The iOP 19-TFT CNC control panel is maintenance free.

Cleaning



Switch off the control computer and all other components connected to the CNC control panel. Disconnect the power supply.



Clean with a soft, damp cloth. Do not use any cleaning fluids or abrasive compounds. Using abrasives may result in the surface of the monitor screen becoming scratched. Make sure that no liquid penetrates the ventilation ports and gets inside the equipment cover.

6 Technical specifications

Dimensions

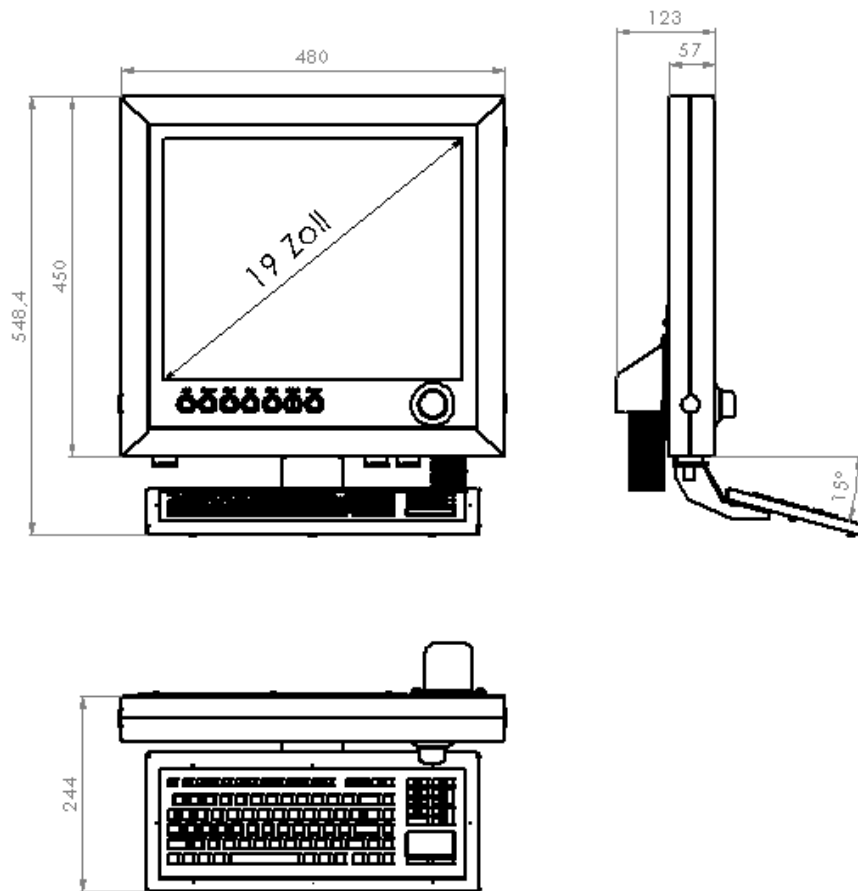

6.1 Technical specifications of the iOP-19-TFT

Properties	
Driver	19" TFT Active Matrix
Viewing angle	75°(horizontal) 60°(vertical)
Pixel size	0.264(H) x 0.264(W)
Viewing area	337 x 270 mm
max. pixel number	1280 x 1024
Colour	24-Bit colour depth 16.2 million
Connections	3 USB ports Pull-out USB 2.0 connection
Power supply:	12V DC, min. 60W, separate power unit required
Degree of protection	iOP-19-TFT IP 50 Keyboard IP 68
Ambient temperature	5°C – 35°C
Storage temperature	-25°C – 55°C
Weight	approx. 15 kg

7 EC Declaration of Conformity



Der Hersteller
The manufacturer

isel Germany AG
Bürgermeister-Ebert-Str. 40
D-36124 Eichenzell

erklärt hiermit, dass folgendes Produkt
hereby declares that the following product

Geräteart: **CNC-Bedienpanel iOP-19-TFT**
Device: CNC-Control-Panel iOP- 19-TFT
Typ: **iOP-19-TFT**
Type:
Art.-Nr.: **iOP-19-TFT: 371100 1000**

Product - No.:

mit den Vorschriften folgender Europäischer Richtlinien übereinstimmt:
complies with the requirements of the European Directives:

EG-Richtlinie 2004/108/EG
EC-Directive 2004/108/EC

EMV Richtlinie
EMC directive

EG-Richtlinie 2006/95/EG
EC-Directive 2006/95/EC

Niederspannungsrichtlinie
low voltage directive

Folgende harmonisierte Normen wurden angewandt:
Following harmonized standards have been applied:

- | | |
|--------------------|---|
| EN 61000-6-2:2006 | EMV - Fachgrundnorm - Störfestigkeit für Industriebereich
<i>EMC - Generic standards - Immunity for industrial environments</i> |
| EN 61000-4-2:2008 | EMV - Prüf- und Messverfahren - Prüfung der Störfestigkeit gegen Entladung statischer Elektrizität (ESD)
<i>EMC - Testing and measurement techniques; Electrostatic discharge immunity test</i> |
| EN 61000-4-4:2012 | EMV - Prüf- und Messverfahren - Prüfung der Störfestigkeit gegen schnelle transiente elektrische Störgrößen (Burst)
<i>EMC - Testing and measurement techniques - Electrical fast transient/burst immunity test</i> |
| EN 61000-4-5:2007 | EMV - Prüf- und Messverfahren - Prüfung der Störfestigkeit gegen energiereiche Impulse (Surge)
<i>EMC - Testing and measurement techniques - Surge immunity test</i> |
| EN 61000-4-11:2005 | EMV - Prüf- und Messverfahren - Prüfung der Störfestigkeit gegen Spannungseinbrüche / Spannungsunterbrechungen
<i>EMC - Testing and measurement techniques - Voltage dips, short interruptions and voltage variations immunity tests</i> |
| EN 61000-6-4:2011 | EMV - Fachgrundnorm - Störaussendung Industriebereich
<i>EMC - Generic standards - Emission standard for industrial environments</i> |
| DIN EN 55011:2011 | Industrielle, wissenschaftliche und medizinische Hochfrequenzgeräte (ISM-Geräte) - Funkstörungen - Grenzwerte und Messverfahren
<i>Industrial scientific and medical (ISM) radio-frequency equipment - Electromagnetic disturbance characteristics - Limits and methods of measurement</i> |

Dermbach, 17.06.2014

Werner Kister, Vorstand / managing board